

Close Coupled In-line Pumps

n = 1450 1/min n = 2900 1/min

---

OPERATING INSTRUCTIONS

# NRC



CE

## GENERAL INSTRUCTIONS

This manual is intended to be a reference guide for users of pumps providing information on

- Pump installation and maintenance instructions,
- Pumps start-up, operation and shut - down procedures.



– This manual should be kept in a safe place and ALWAYS be available to the QUALIFIED operating and maintenance personnel responsible for the safe operation and maintenance of the pumps.

- Qualified personnel should be experienced and knowledgeable of safety standards.
- To avoid faulty operation and malfunctioning of pumps the instructions in this manual are to be CAREFULLY studied and followed at all stages of the pump installation and operating life.
- The user is responsible for ensuring that inspection and installation are carried out by authorized and qualified personnel who have studied this manual carefully.
- The pump should be used ONLY in the operating conditions given on the order for which the pump and materials of the construction have been selected and tested.
- If the pump is to be used for a different application please contact sales office or representative of the manufacturer. WT refuses to assume any responsibility if the pump used for different applications without prior written permission.
- If the pump is not to be installed and operated soon after arrival, it should be stored in a clean and dry place with moderate changes in ambient temperature. Extreme low or high temperatures may severely damage the pump unless suitable precautions are taken. The user is responsible for the verification of the ambient conditions where the pump will be stored or installed.
- WT does not guarantee repairs or alterations done by user or other unauthorized personnel. The use of original spare parts and accessories authorized by manufacturer will ensure safety.
- This manual does not take into account any site safety regulation, which may apply.

## SAFETY INSTRUCTIONS



***Strictly obey to the following instructions to prevent personal injuries and/or equipment damages:***

- Pump should be used only in the specified operating conditions.
- Any weight, stress or strains on the piping system should not be transmitted to the pump.
- Electrical connections on the motor or accessories must always be carried out by authorized personnel and in accordance to the local codes.
- Any work on the pump should be only carried out when the unit has been brought to standstill.
- Always disconnect the power to the motor and make sure not be switched on accidentally before working on the pump or removing the pump from installation.
- Any work on the pump should be carried out by at least two persons.
- When approaching the pump always be properly dressed and/or wear safety equipment suitable for the work to be done.
- Do not work on the pump when it is hot.
- Do not touch the pump or piping with temperatures higher than 80° C. User must take suitable precaution to warn the persons (e.g. using warning signs, barrier).
- Always be careful when working on pumps that handling dangerous liquids (e.g. acids or hazardous fluids).
- Do not work on the pump when the pump and piping connected to the pump are under pressure.
- After completion of the work always fix the safety guards back in places previously removed.
- Do not run the pump in the wrong direction of rotation.
- Do not insert hands or fingers into the pump openings or holes.
- Do not step on the pump and/or piping connected to the pump.

# NRC

## 1. GENERAL

### 1.1 Pump Description

- NRC series pumps are radially split volute casing, single stage, close-coupled, in-line centrifugal pumps with closed impeller and mechanical seal.
- Main dimension of casing complies with EN 733/DIN 24255.
- NRC pumps can be installed either pipe-supported in sufficiently anchored pipework or base mounted on a foundation.

### 1.2 Applications

NRC series pumps are suitable for clean or slightly contaminated (max. 20 mg/dm<sup>3</sup>) liquids with low viscosities and temperatures up to 110° C. The main application areas, among others, are

- Water supply systems,
- Warm water heating, chilled and cooling water systems.
- Water systems for industrial uses,
- Industrial circulating systems,
- Fire fighting

### 1.3 Technical Data

Speed	: 1450-2900 rpm
Discharge Nozzle	: DN 40 up to 200 mm
Suction and discharge Flanges	: DIN 2533/PN 16
Operating Temperature	: -10° C up to 110° C
Ambient Temperature (max)	: 40° C
Casing Pressure (max)	: 16 bar 10 bar
Permissible liquids	: See 1.2
Insulation Class	: F
Enclosure Rating	: IP 55
Electrical Connection	: 3 ph-400V- 50 Hz
Special motor version (on request)	: Special voltage, frequency

## 2. UNCRATING, TRANSPORT AND STORAGE

### 2.1 Uncrating

- Upon receipt verify that the goods received are in exact compliance with that listed on the packing list.
- Check that no visible damage exists on the crate that could have occurred during transportation.
- Carefully remove the packaging material and check that pump and accessories (if any) are free from any markings, stretches and damages, which may have occurred during transportation.

- In the event of damage report this immediately to WT's service department and to the transport company.

## 2.2 Transport

### - *General Recommendations*

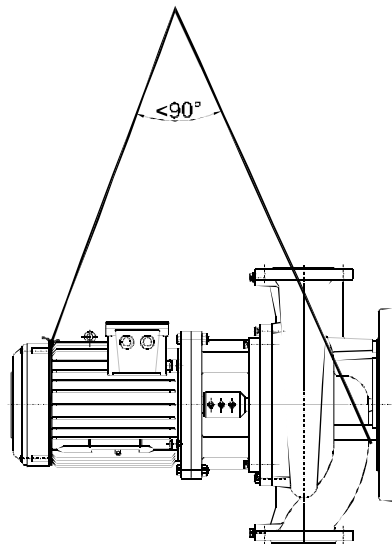


- Existing regulations for the prevention of accidents must be followed.
- Wearing of gloves, hard-toed boots and hard hats is obligatory for all transport works.
- Wooden cases, crates, pallets or boxes may be unloaded with fork-lift trucks or using hoisting slings, depending on their size, weight and construction.

### - *Lifting*

- Prior to lifting and moving the pump set find out the following:
  - Total weight and center of gravity
  - Maximum outside dimensions
  - Lifting points location
- The load-bearing capacity must be proper to the weight of the pump or the pump set.
- The pump set must always be raised and transported in horizontal position.
- It is absolutely forbidden to stand beneath or nearby a raised load.
- A load should never remain in a raised position for longer than necessary.
- Accelerating and braking during the lifting process must be performed such that there is no danger to persons.

When lifting the pump set lift them as shown in *Fig.1* to avoid any distortion (especially do not use the motor eyebolt for carrying the complete unit).



*Fig. 1 Pump set*

## 2.3 Storage

- If the pump is not to be installed and operated soon after arrival, store the pump in a clean, dry and frost-free place with moderate changes in ambient temperature.
- To prevent the pump from moisture, dust, dirt and foreign materials suitable steps should be taken.
- The pump shaft should be revolved periodically (e.g. once a week) to prevent pitting of the bearing surfaces and the pump from seizing up.

### 3. INSTALLATION ON SITE

**ATTENTION** Installation has to be carried out in accordance with EN 60204.

The pump should only be installed, leveled up and aligned by skilled personnel. Incorrect installation or defective foundation could result in troubles. This would not be covered by the warranty.

#### 3.1 Preparation for Installation

Before installing the pump clean the suction and discharge flanges thoroughly.

#### 3.2 Installation Site

**ATTENTION**

- The pump must be installed in a frost and dust-free, well-ventilated and non-explosive environment.
- The pump should be installed such that there is space for access, ventilation, maintenance and there is sufficient space above the pump for it to be lifted.
- The suction pipe should be kept as short as possible.

#### 3.3 Installation

NRC pump can be installed either pipe-supported on sufficiently anchored pipework or base mounted on a foundation.

- **Pump Installed on Pipe**

- NRC pumps can be installed on straight pipes in horizontal or vertical position.
- When pump mounted on a vertical pipe the flow may be from up to down or reverse direction.
- When pump mounted on a horizontal pipe, the motor axis may be horizontal or vertical position but it MUST NEVER fall below the horizontal line.

**ATTENTION**

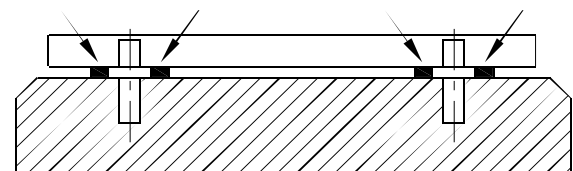
See **Fig. 12** in **section 11**. for permissible installation arrangements.

- **Pump Installed on Foundation**

NRC pump can be installed on a foundation with special base plate for vertical mounting on flexible pipes.

**ATTENTION**

- The greatest care must be taken in preparing the foundation and mounting the pump set. Incorrect installation will result in premature wear of pump components and break down of the pump.
- The foundation should be heavy enough to reduce vibrations and rigid enough to avoid any twisting or misalignment. Make sure the concrete foundation has set firm and solid before mounting the pumpset. The surface of the foundation should be truly horizontal and perfectly flat.
- Place the pumpset on the concrete and by adding or removing shims under the baseplate align the pump flanges vertically as shown on **Fig.2**.
- Slightly tighten the anchor bolts.
- Wait until the concrete firmly set (minimum 3 days).
- Tighten the anchor bolts.

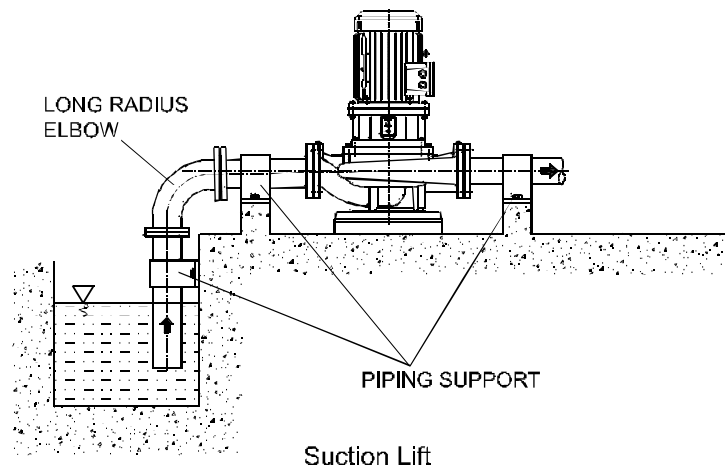


**Fig. 2** Foundation, baseplate and fitting the shims

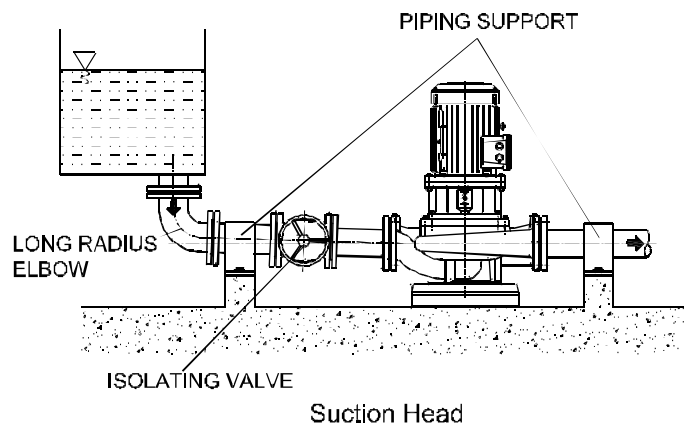
### 3.4- Connecting the Piping

#### - General

- Never use the pump as an anchorage point or as a carrier for the piping.
- The pipes should be supported very near the pump (*Fig. 3*). It must be checked that any weight, stress or strains on the piping system should not be transmitted to the pump. Therefore after completing the piping installation, the bolt and connection on the suction and discharge nozzles must be loosened to ensure that there is not any stress on the piping system to the pump.
- The nominal sizes of the pump suction and discharge nozzles are no guide to the correct sizes of the suction and discharge piping. The nominal bores of the pipes should be same as or greater than those of the pump nozzles. Never use pipes or accessories which have smaller bore than the pump nozzles. Particularly foot valves, strainers, filters and non return valves must be preferred with larger free transition areas. In general the flow velocities should not exceed 2 m/s in the suction piping and 3 m/s in the discharge piping. Higher flow velocities will result in higher pressure drops, which could cause cavitation conditions in the suction piping and excessive friction losses in the discharge piping.



- Pipe joints should be by means of flanges with flange gaskets of proper size and material. Flange gasket must be centered between the flange bolts in a such way that there is no interference with the flow of the liquid.
- Thermal expansions of the pipework and excessive vibrations should be accommodated by suitable means so as not to impose any extra load on the pump.



*Fig. 3*

- Prevent impurities such as welding beads, scale, sand and tow might be left in pipes while production of the piping system harms the pump. Seal the pump nozzles by means of blind gasket to stop impurities get in the pump. After assembling the system all the piping parts must be disassembled, thoroughly cleaned, painted and reassembled again. If a strainer is used on the suction side of the pump, it must be cleaned after several days of operation.

#### - Suction Piping (*Fig. 4*)

- The suction piping must be absolutely leak-tight and not present any features likely to promote the formation of air pockets. Suction piping therefore should have a slight downward slope towards the pump in the case of suction head installation (e.g. flooded suction) and slight upward slope towards the pump in the case of suction lift installation.

- In order to keep the pipe friction losses as low as possible it is essential to avoid any sharp bends and abrupt changes of direction or cross-section and the suction pipe should be kept as short as possible. If it is necessary to change the cross-section of a piping laid almost horizontal, an eccentric reducer, with top horizontal, should be used.
- A positive suction head piping should incorporate an isolating valve with the valve stem in the horizontal position. This valve should always remain fully open while the pump is running and must not be used to regulate the flow.

- **Discharge Piping (Fig. 4)**

- A control valve should be installed in the discharge pipe, as close to the pump as possible, to regulate the required flow and head.
- If the total head of the pump exceeds 10 meters or if discharge line is of appreciable length a non return valve should be installed between the pump and isolating valve on the discharge line to protect the pump against water hammer and reverse flow on shut down.

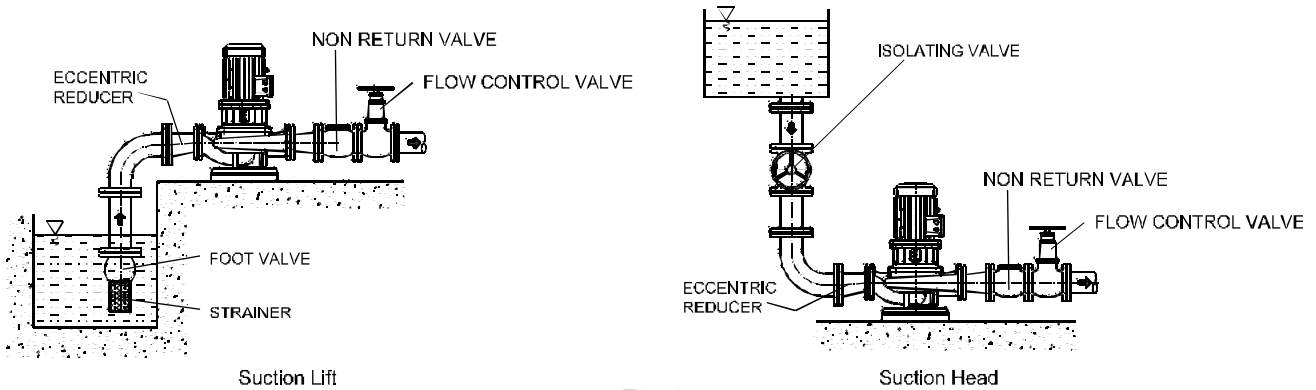
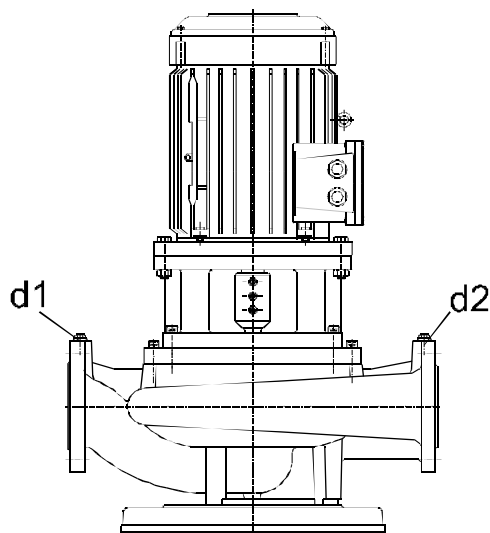


Fig. 4

- **Pressure Gauge Connections**

- Pressure and vacuum gauges must be properly anchored and connected at the measuring points located on the pump flanges (Fig. 5) or on the pipes close to the flanges approximately 8 mm diameter tubing with pig tail configuration to lessen pressure fluctuation. For safety purposes isolating and vent valves should be fitted before the gauges (Fig. 6).



- d1: Pressure gauge (suction).
- d2: Pressure gauge (discharge).

Fig. 5.

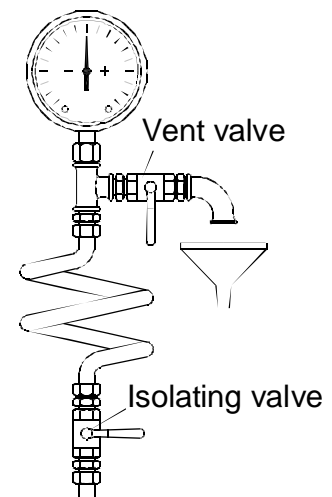


Fig. 6.

- **Minimum Flow**

If there is a possibility of the pump having to operate at zero flow (against a closed discharge valve) or near the closed valve with almost no flow, then a minimum flow valve (or a by-pass check valve) must be installed on the discharge nozzle or on the discharge piping right after the pump but before the flow regulating valve. In cases where there is no such a valve operating the pump against close valve for a long time causes considerable damage on the pump since almost all the motor power is transformed into thermal energy which is absorbed by the pumped liquid.

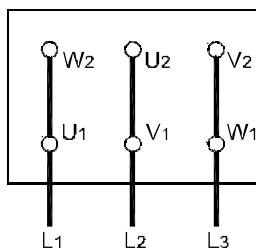
**3.5 Electrical Connections**



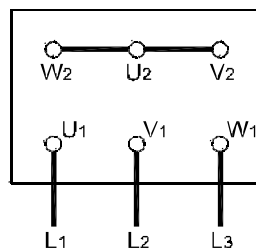
- The electrical engines have to be built in accordance with EN 60034-1.
- Enclosures of electrical motors and control systems on the pump unit shall as a minimum give protection in accordance with EN 60529 IP22. But in determining the degree of protection of enclosures of electrical motors and control systems on the pump unit the operating and environmental conditions must be taken into consideration.
- Electrical connection should be done by a qualified electrician. Current national regulation and motor manufacturer's instructions must be observed.
- Take all safety precautions listed in "Safety instructions." Disconnect all power supplies prior to doing any work.
- The supply cable must be laid in such a way that it never touches the pipework, pump and motor casing.
- Check voltage, phase and frequency on motor nameplate with the mains.
- The electric motor must be protected against overloading by means of circuit breakers and/or fuses. Circuit breakers and fuses must be selected in accordance with full load amperage of the motor appearing on the motor rating plate.
- It is recommended to use PTC (passive thermal control) on motor, but this is optional depending on customer requirement. In case of using PTC, these should be connected via corresponding terminals in the terminal box and the PTC should be connected to the thermal trip mechanism.
- Prior to connecting the electrical wiring rotate the pump shaft by hand to make sure rotor rotates easily.
- Connect the electrical wiring in accordance with local electrical codes and make sure to ground the motor.
- The connection diagram can be found in the terminal box of the motor or in the instruction manual.
- The mains connection on the tagboard depends on the nominal power of the motor, the power supply and the type of connection. The necessary connection of the bridges in the terminal box is shown in the following (*Table 1. and Fig. 7a, 7b, 7c*).

**Table 1**

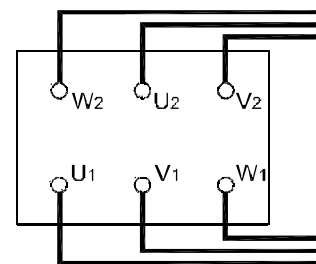
Type of switch	Power of motor $P_N \leq 4 \text{ kW}$	Power of motor $P_N > 4 \text{ kW}$
	power supply 3 ~ 400 V	power supply 3 ~ 400 V
direct	Y – connection (7b)	$\Delta$ – connection (7a)
Y / $\Delta$ - start	Impossible	Remove connecting bridges (7c)



**Fig. 7a.  $\Delta$  - Connection**



**Fig. 7b. Y – Connection**



**Fig. 7c. Y /  $\Delta$  - Start**



**ATTENTION**

In the case of three-phase induction motors with Y – Δ – connection it must be ensured that the change-over points between star and delta follow on from one another very quickly. **Longer change-over times may result in pump damage (Table 2).**

**Table 2**

power of motor	Y – time to be set
≤ 30 kW	< 3 sec.
> 30 kW	< 5 sec

**3.6 Final Check**

- After completion all the above process rotate the pump rotor several times by hand. Make sure rotor rotates easily.
- Fix the safety guards back in places. Do not operate the pump before doing so. This is a necessity for security and job safety.

**4. START UP / SHUT DOWN****4.1 Preparation****- Lubrication Control**

Since the bearings of motor are life-time lubricated type, they are maintenance free.

**- Check the Shaft Seal (see 6.3)****- Venting and Priming**

Make sure that the pump and suction pipes are completely filled up with water before the pump is started.

- There is no problem for the pumps which have positive suction head. Close the discharge valve and remove the plug from one of the pump flanges, depending on the pump location, and gradually open the isolating valve in the suction pipe until a steady stream of water run out. Then screw the plug and completely open the isolating valve.
- If there is a foot valve for the pump, which has suction lift, remove the plug from one of the pump flanges and fill up with water through the hole using a funnel, hose or a similar device.
- If the system has a vacuum pump, water is brought up in the rising pipe and filled up the pump through this vacuum pump. When water is risen up to the highest point then the pump is started up.

**ATTENTION**

**: Make sure the pump never runs dry.**

**- Checking the Direction of Rotation**

- **NRC** type pumps rotate in clockwise when it is looked from motor to the pump. This direction is already indicated on the pump nameplate by an arrow. Check this by switching the pump on, then off again immediately. Fit the safety guard back in place if you took it out.

**4.2 START UP THE PUMP**

- Check if the shut off valve in the suction line is open and the shut off valve in discharge line is closed.
- Switch on the circuit breaker and run the motor.
- Wait until the motor reaches the full speed (on star-delta running motors wait until it switches on delta).
- Open the discharge valve slowly while watching the ampermeter on the control panel (If the discharge line is empty do not turn on the valve fully open on first start up. Turn it on slowly to maintain the value on the ampermeter is under the rated current value of the motor).

- When the valve is if fully open, check the pressure on the manometer and see it is the same with the duty point pressure. If the pressure on the pressure gauge is lower than duty point pressure brings them to the duty point value by slightly closing the valve. If it is higher value, check your installation, particularly head again.

**ATTENTION** : The pump should be shut down at once and the trouble should be corrected if the pump is running at its rated speed and found any of the following faults:

- Pump doesn't deliver any water,
- Pump doesn't deliver enough water,
- Flow is going down,
- Discharge pressure is not enough,
- Driver overloaded,
- Vibration on pump,
- High noise level,
- Bearing overheating

### 4.3 SHUT DOWN THE PUMP

- Slowly close the shut-off valve in the discharge line.
- You may shut down the pump without closing the shut-off valve if there is a device for water hammer protection on the discharge line or the water hammer is not a considerable level.
- Switch off the driver. Ensure the pump set runs down smoothly and quietly to a standstill.
- If the set is to remain out of services for a long time close the shut-off valve in the suction pipe. In the event of frost and/or prolonged standstill, drain the pump or otherwise protect against freezing.

### 4.4 CHECKS TO BE MADE WHILE THE PUMP IS RUNNING

- The pump must run smoothly, quietly and free from vibration at all times.
- The pump must never run dry.
- Never run the pump for along period against a closed discharge valve (At zero flow).
- The bearing temperature may exceed the ambient temperature by up to 50° C. But must never rise above 80° C.
- The pump has a mechanical seal, these will experience only minor leakage or no visible leakage during operation. It is maintenance free. If there is considerable leakage from the seal, that means the seal surfaces are worn-out and it needs to be replaced. The operation life of the mechanical seal highly depends on the purity of the water.
- Occasionally check the motor current. Stop motor if the amperage is higher than usual; there may be jamming or friction in the pump. Make the necessary mechanical and electrical checks.
- Stand-by pumps should be run for a short time at least once a week to ensure they are in constant readiness for operation. Check the integrity of auxiliary connections.

## 5. LUBRICATION

The bearings of motor are always life-time grease lubricated and then maintenance-free.

### ATTENTION

- The bearing temperature may exceed the ambient temperature by up to 50° C. But never rise above 80° C.
- Do not reuse the bearings following disassembly for maintenance purposes.

## 6. DISASSEMBLY, REPAIR AND REASSEMBLY

### ATTENTION

- Before starting work on the pumpset, make sure it is disconnected from the mains and can not be switched on accidentally.

## 6.1 DISASSEMBLY

- Close all valves in the suctions and discharge lines.
- Remove the safety guard (See **section 12** for safety guard).
- Detach pump suction and discharge flanges and all auxiliary supply lines (if any), disconnect the pump set from the piping system.
- Dismantle the volute casing (01) from the stuffing box cover (46) (Be careful to keep the stuffing box cover in place to avoid any mechanical seal trouble).
- Unscrew the end nuts (65) of the impeller and take out the impeller (50) and impeller key (210). Use rust remover solvent if necessary during dismantling.
- Take out the spacer sleeve (67).
- Pull out the rotating part of the mechanical seal (405).
- Dismantle the seal cover (46) and take out the stationary part of the mechanical seal from the seal cover.
- Dismantle the motor pedestal (12).
- Unscrew the set-screws (380) of the pump shaft (60), or alliens of the rigid coupling (85) depending on connection type.
- Pull off the pump shaft (60) from the motor shaft.

## 6.2 REASSEMBLY

- Reassembly proceeds in reverse sequence to disassembly as described in section 6.1. You may find the attached drawings useful (*see sectional drawing in section 10.*).
- Coat the seats and screw connections with graphite, silicon or similar slippery substance before reassembly. If you can not find any of the above you may use oil instead (except the pumps for drinking water).
- Never use the old o-rings and make sure the o-rings are the same size as the old ones.

### A- For Motor Frame Size up to 200 (See Fig. 10 in section 10.)

- Place the motor (600) vertical as the shaft end comes to the upper side.
- Assemble the motor pedestal (12) to the motor (600).
- Slip the pump shaft (60) onto the motor shaft.
- Place the stuffing box cover (46) onto the motor pedestal (12)
- Make the alignment of the pump shaft's location to provide the length as per the length "S". ("S" is the distance between the shaft shoulder and the end of the mechanical seal chamber. (**See Fig. 8**). Tighten the set-screws (for the shaft consists of 3 set - screws starting from the one in the middle and if or the shaft consists of 2 set-screws start from the one near the motor).
- Place the stationary part of the mechanical seal into the seal chamber.
- Slip the rotating part of the mechanical seal onto the pump shaft (60) and place the spacer sleeve (67).

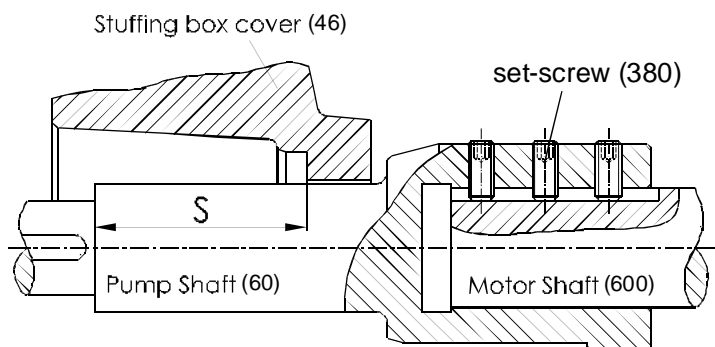
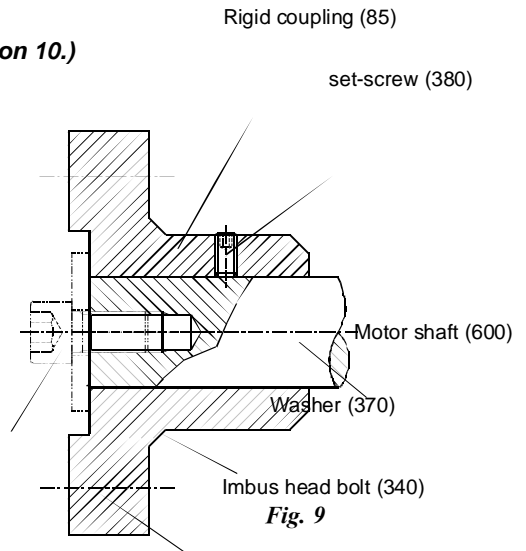


Fig. 8

- Place the impeller key (210) into keyway, slide the impeller (50) onto the shaft (60) and screw the impeller nuts (65).
- Assemble the volute casing (01).
- Mount the base plate (11) to the pump (if used).

**B- For Motor Frame Size Above 200 (See Fig. 11 in section 10.)**

- Place the motor (600) vertical as the shaft end comes to the upper side.
- Slip the rigid coupling (85) onto the motor shaft (60) put the washer (370) on the rigid coupling (85) and tighten by using imbus head bolt (340). So that the shaft end and the coupling end will be on the same plane (see Fig. 9).
- Tighten the set-screw (380) over the rigid coupling (85).
- Mount the pump shaft (60) to the rigid coupling (85).
- Place the stuffing box cover (46) onto the motor pedestal (12).
- Place the stationary part of the mechanical seal into the seal chamber.
- Slip the rotating part of the mechanical seal onto the pump shaft (60) and place the spacer sleeve (67).
- Place the impeller key (210) into keyway, slide the impeller (50) onto the shaft (60) and screw the impeller nuts (65).
- Assemble the volute casing (01).
- Mount the base plate (11) to the pump (if used).



### 6.3 SHAFT SEAL

**NRC type pumps are with mechanical shaft seals.**

- When operating properly the mechanical seal has no visible leakage. Usually mechanical seals do not require maintenance until leakage is visible but its tightness is to be checked regularly.
- Follow the instructions of mechanical seal manufacturers for the pumps having mechanical seals and NEVER RUN IT DRY!
- Mechanical seal diameters are given in *Table 3*.

### 7. SPARE PARTS

- **WT** guarantees to supply the spare parts for NRC type pumps for 10 years. You can provide any spare parts easily.
- Lets us know the following details on the name-plate, when you order spare parts.

<b>Pump Type and size</b>	: ( NRC 125-315)
<b>Motor power and size</b>	: ( 22 Kw – 1450 rpm)
<b>Production Year and Serial Number</b>	: ( 1992 – 13987 )
<b>Capacity and Head</b>	: ( 200 m <sup>3</sup> /h – 30m )

- If you prefer to have spare parts in your stock, we recommend you to have the following quantities for a two years operation depending on the number of same type of pumps (*Table 3*).

**Table 3**

Part No	Part Name	Number of pumps in the system						
		2	3	4	5	6-7	8-9	10+
60	Shaft (Incl. Keys)	1	1	2	2	2	3	30%
50	Impeller	1	1	1	2	2	3	30%
20 – 21	Wear rings (if any)	2	2	2	4	4	6	50%
420	O-Rings for casing	4	6	8	8	9	12	150%
405	Mechanical seal	2	3	4	5	6	7	40%
67	Spacer sleeve	1	1	1	3	2	2	20%

## 8. FAULTS, CAUSES and REMEDIES

In this section you will find operating faults which may arise, and their causes (*Table 4*), and suggested remedies (*Table 5*).

### ATTENTION

Before remedying operating faults, check all measuring instruments used for reliability and accuracy.

**Table 4**

FAULTS	POSSIBLE CAUSES
Pump doesn't deliver any water after start-up	1-5-7-10-11-13
Flow is going down or no flow at all	2-3-8-14
Driver overloaded	9-12-17-22
Bearings overheating	18
Vibration on pump	15-16-19-20
Noise level is high	4-6-21

**Table 5**

	POSSIBLE CAUSES	REMEDIES
1	There may be air existing in pump or suction pipe	Fill pump and suction pipe completely with liquid and repeat the priming procedure.
2	Ingress of air through shaft seal, suction pipe or suction port. Pump lifts liquid with air	Check for leaks in suction pipe joints and fittings. Check shaft seal if necessary increase the pressure of sealing liquid. Check the dept of suction pipe or foot valve in the liquid and if necessary increase the depth of them.
3	Air pocket in the suction pipe.	Check the slope of the suction line make sure that there is no reason for formation of air pockets.
4	There is air in liquid	Suction pipe is not submerged enough creating vortex. Check liquid level in suction tank or increase the depth of suction pipe or foot valve in the liquid.
5	Too much suction	If no obstruction at inlet check the friction losses of suction line, larger piping may correct condition. If static lift is too high, the liquid level in the suction tank must be raised or the pump lowered.
6	Pump is working at cavitation conditions	NPSH available is too low. Check liquid level in suction tank, check suction line for excessive friction losses. Check isolating valve in suction line to make sure it is completely open. If necessary increase suction head on pump by lowering the pump.
7	Insufficient manometric head.	The actual total head is higher than that originally specified. Check the geodetic total head and friction losses in the discharge line. Larger piping may correct the condition. Check that valves are fully open.

8	Increase at total manometric head.	Check that valves are fully open. Check that there is any obstruction in discharge pipe.
9	Pump is operating at lower manometric head.	The actual total head is lower than that originally specified. Machine impeller outer diameter to size advised by supplier.
10	Reverse rotation.	Check motor rotation with directional arrow on pump casing or nameplate.
11	Speed is too low.	Check the supply voltage and frequency or motor may have open phase.
12	Speed is too high.	If possible decrease the pump rotational speed or turn down the impeller outer diameter to size advised by supplier.
13	Impeller or check valve or strainer is clogged.	Clean the impeller or check valve or strainer.
14	Impeller or strainer is clogged partially.	Clean the impeller or strainer.
15	Partially clogged impeller.	Clean the impeller.
16	Worn out and defected impeller.	Replace impeller.
17	Mechanical frictions inside the pump.	Check pump rotor for any rotor obstruction or deflection.
18	The pumped flow is less than the minimum flow required.	Increase the flow. If necessary use by-pass recirculating valve or line.
19	Oblique shaft.	Check the and replace it if necessary.
20	Unbalanced rotating parts.	Check the balance of the rotating parts.
21	Pump runs out of duty range.	Check the values of operating point.
22	Defects in motor.	Check any motor defects. The motor may not be ventilated properly due to a poor location.

## 9. TIGHTENING TORQUES

Thread Diameter	Tightening Torque max (Nm)	
	Property Classes	
	8.8	10.9
M4	3.0	4.4
M5	5.9	8.7
M6	10	15
M8	25	36
M10	49	72
M12	85	125
M14	135	200
M16	210	310
M18	300	430
M20	425	610
M22	580	820
M24	730	1050
M27	1100	1550
M30	1450	2100
M33	1970	2770
M36	2530	3560



- For motor frame size above 200

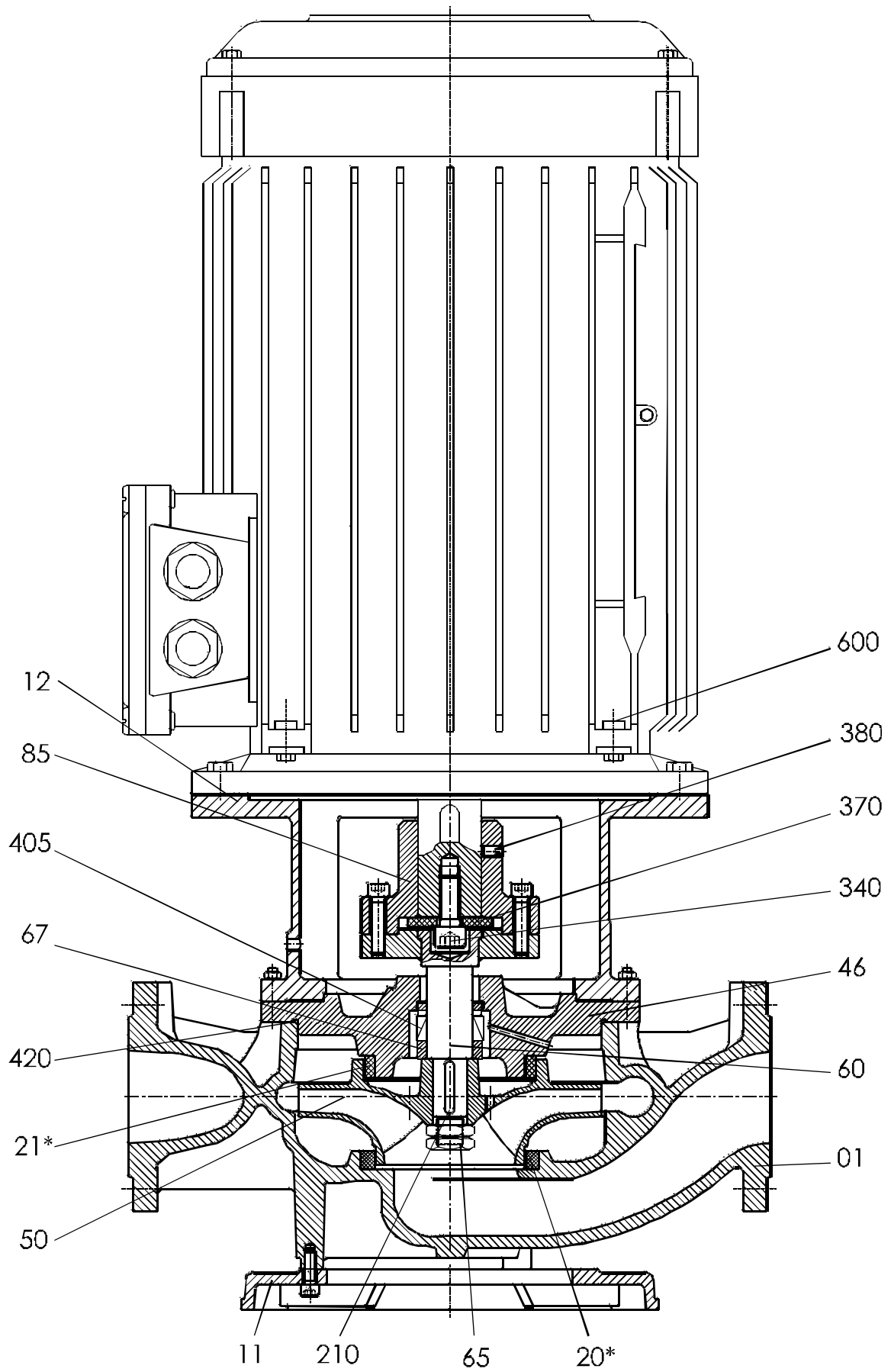
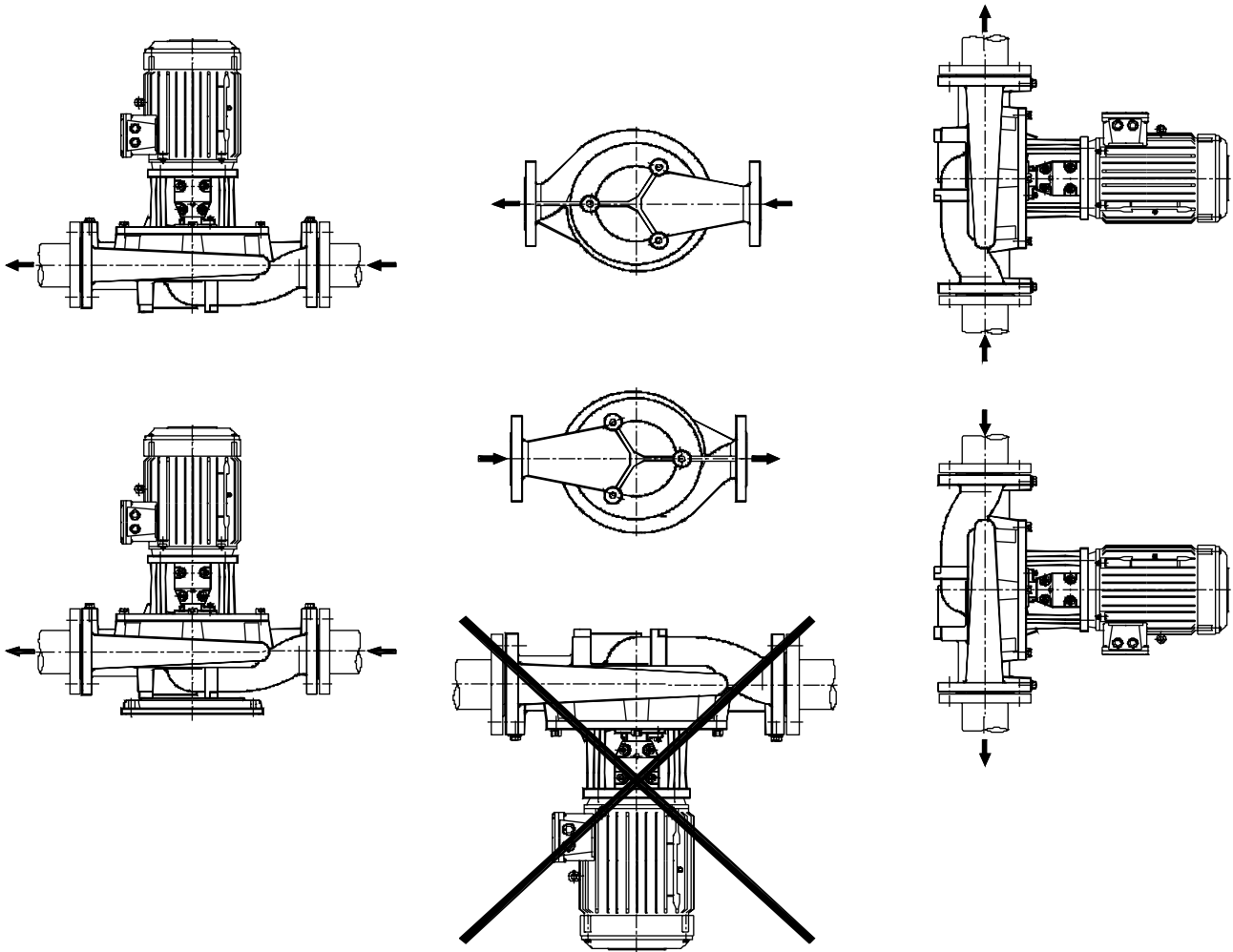


Fig. 11

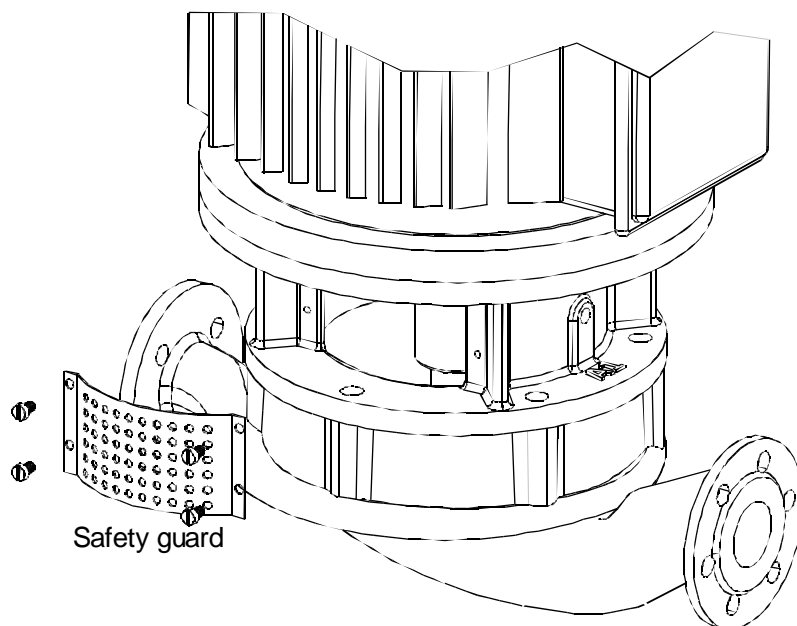


## 11. PERMISSIBLE INSTALLATION ARRANGEMENTS

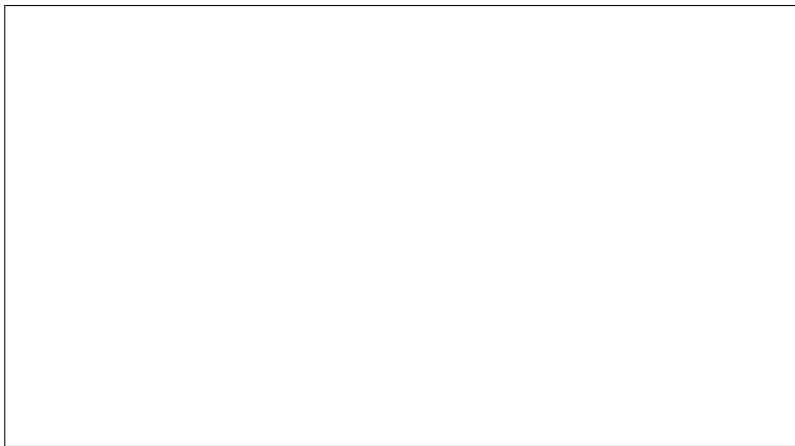


*Fig. 12*

## 12. SAFETY GUARDS



**Note : All guards are conforming to EN 294.**



**SAVE THESE INSTRUCTIONS**



**Address:**

Via XXI Luglio 20  
41037 Mirandola (Mo) - Italy

**Contacts:**

Tel: +39 051 0830573  
Fax: +39 0535 658 353

[info@watertechnologies.it](mailto:info@watertechnologies.it)